**WARNING**

1. Use this product only one person at a time.
2. Do not use this chair unless all bolts screws and knobs are securely tightened.
3. Check that all bolts screws and knobs are tight every three months or as needed.
4. Dispose of packing material properly. Do not use plastic cover as head covering. It may cause suffocation.
5. Do not use chair as a stepladder.
6. Use this chair for its intended purpose only.
7. Use mild detergent only for cleaning.

LIMITED WARRANTY

Pro-Line II chairs are warranted* from the date of purchase against failure due to material and workmanship as follows:

- Lifetime on component parts including pneumatic cylinder, control mechanism, base and casters.
- 3 Years on upholstery fabric and foam against wear and deterioration.
- We can not warrant leather against routine scratching and scuffing, as all leather is subject to minor blemishes in normal use.

To make a warranty claim, contact Parts Department. Provide model number and description of the problem and obtain return authorization.

At it's option Office Star Products will:

- (a) Supply compatible components of current manufacture.
- (b) Repair the customer's component. The customer must prepay freight on any components returned to the factory.

Return freight on components still in warranty will be paid by Office Star Products.

**All warranties are limited to the original purchaser for normal commercial usage defined as a standard forty hour work week by persons weighing 250 lbs. or less. This warranty will not cover labor, freight or damage from misuse, abuse, negligence, alteration, accident, vandalism, rusting, acts of nature or any other event beyond the control of Office Star Products. The warranty does not cover cosmetic damage that may result from normal use. Liability for incidental or consequential damages is excluded. The user assumes all risk of injury resulting from use of this product. When usage is more than 40 hours per week, a five year warranty on all parts applies. Fabric and foam is warranted for one year. This warranty gives you specific legal rights, and you may also have other rights which vary from state to state.*

Our quality standards are among the highest in the industry. Sometimes, no matter how hard we try, there are times when parts are damaged or missing. Our Parts Department will do everything possible to promptly remedy the problem. Contact us via e-mail parts@officestar.net, by Fax 1-909-930-5629, or toll free parts number 1-800-950-7262, Monday through Friday 8:00 a.m. - 5:00 p.m. Pacific Time.

STEP 1

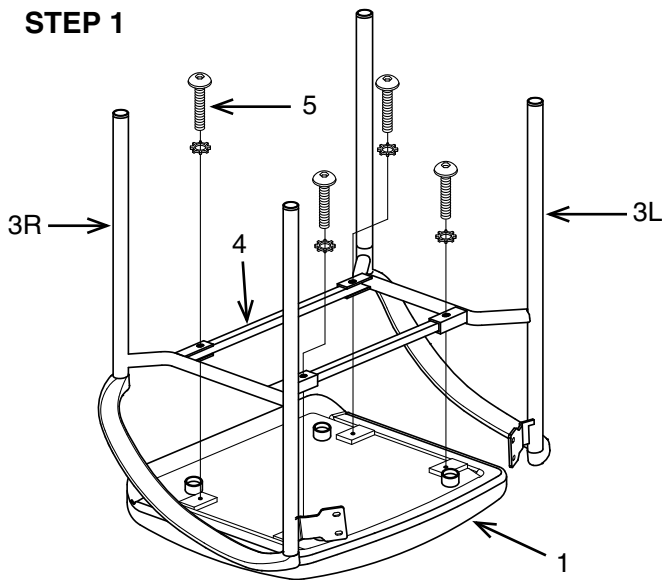

STEP 2

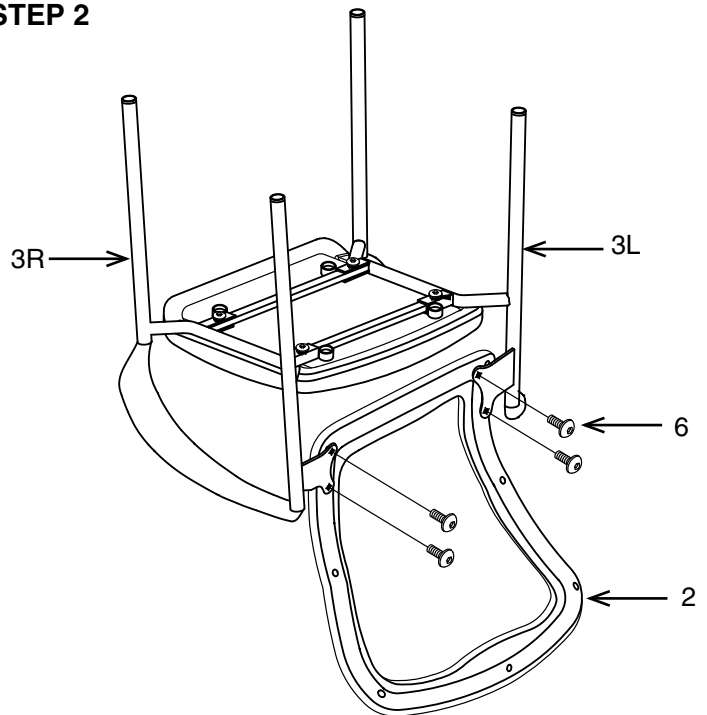

STEP 3

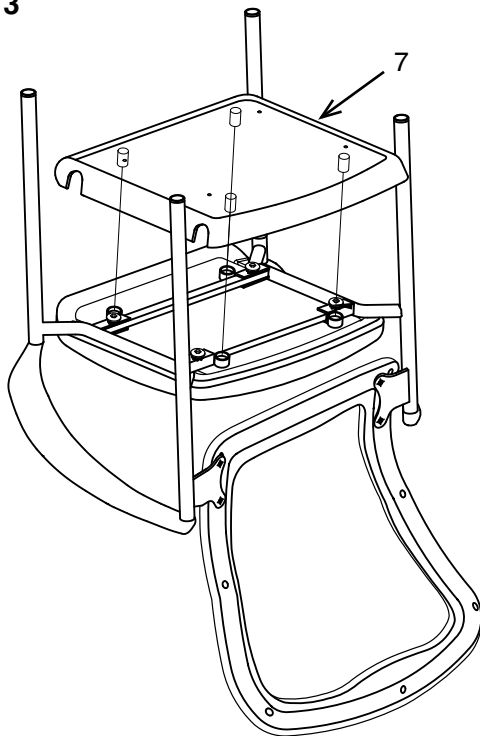

PART	QTY
1. Seat Cushion.....	1
2. Backrest.....	1
3. Arm Frame (3L & 3R).....	2
4. Cross Bar.....	2
5. Screw w/ Washer.....	4
6. Backrest Screw.....	4
7. Plastic Cover.....	1
8. Allen Wrench (not shown).....	1

Remove all parts from carton, separate by part numbers indicated on parts list, and verify part quantities.

STEP 1 Attach Cross Bars (4) between Arm Frames (3L & 3R) and secure to bottom of Seat Cushion (1) using four Screws w/ Washers (5), **FULLY TIGHTEN ALL SCREWS USING ALLEN WRENCH (8).**

STEP 2 Secure Backrest (2) to Arm Frames (3L & 3R) using four Backrest Screws (6). **FULLY TIGHTEN ALL SCREWS USING ALLEN WRENCH (8).**

STEP 3 Attach Plastic Cover (7) to bottom of chair assembly by applying pressure and snapping it into place.

ATTENTION: MAKE SURE ALL SCREWS ARE FULLY TIGHTENED BEFORE USING CHAIR.